Incorporation in Danish: Implications for interfaces

ASH ASUDEH AND LINE HOVE MIKKELSEN

1.1 Introduction¹

Syntactic noun incorporation (SNI) in Danish is a phenomenon that has reflexes in phonology, syntax, semantics and pragmatics. In contrast with morphological noun incorporation, which involves compounding of an N stem and a V stem to yield a larger, derived V stem (Mithun, 1984, 847), SNI does not involve any overt word order perturbation or overt morphology, but is rather expressed prosodically. However, SNI shares essential semantic and pragmatic characteristics of morphological noun incorporation (in particular, Mithun's (1984) type I incorporation).

Although there is a large body of descriptive work on SNI (see Rischel and Basbøll (1995) and references cited there), there have been few attempts to give a formal analysis of the phenomenon (a notable exception is Hentze (1996)). As an information-theoretic, sign-based framework, HPSG is especially well-suited for a formal treatment of SNI that simultaneously captures generalizations in all four areas as well as interactions between them. Building on work by Abeillé and Godard (2000), Bird and Klein (1994), and Meurers (1995, 1999), we propose a lexical account of SNI that introduces non-trivial extensions to HPSG phonology. However, we follow the descriptive literature on the Danish phenomenon in using the term 'syntactic noun incorporation'.

¹We would like to thank Mike Calcagno, Edward Flemming, Paul Kiparsky, Paula Monachesi, Chris Potts, Geoff Pullum, Ivan Sag, Ida Toivonen, two anonymous reviewers, and audiences at Stanford, HPSG99, and the University of Ottawa for their comments. None of these people should be held responsible for any remaining errors. Asudeh's work is partially funded by SSHRC Doctoral Fellowship 752-98-0424.

1.2 The data

The (a) sentences below are examples of SNI, while the (b) and (c) sentences show contrasts with ordinary object DPs. Following Nedergaard Thomsen (1992), we use $\underset{\cdot}{\circ}$ to indicate reduced stress and $\overset{\cdot}{\circ}$ to indicate a word with regular word stress. For simplicity we indicate stress at the left edge of a word. Phonological phrasing is indicated using square brackets.² Note that we use ‘phonological phrase’ as a general term for a phonological constituent, not as a name for a particular phonological constituent of a particular size (i.e. we are not making claims about Phonological Phrases versus Intonational Phrases or Intermediate Phrases, etc).

- (1) a. Min nabo [$\underset{\cdot}{\circ}$ k**ø**bte $\overset{\cdot}{\circ}$ hus] sidste år.
 My neighbour bought house last year
 ‘My neighbour did house-buying last year.’
 ~‘My neighbour bought a house last year.’
- b. Min nabo [$\underset{\cdot}{\circ}$ k**ø**bte] [$\underset{\cdot}{\circ}$ et $\overset{\cdot}{\circ}$ hus] sidste år.
 My neighbour bought a house last year
 ‘My neighbour bought a house last year.’
- c. Min nabo [$\underset{\cdot}{\circ}$ k**ø**bte] [$\underset{\cdot}{\circ}$ hus.et] sidste år.
 My neighbour bought house.DEF last year
 ‘My neighbour bought the house last year.’
- (2) a. Har du [$\underset{\cdot}{\circ}$ redt $\overset{\cdot}{\circ}$ seng]?
 Have you made bed
 ‘Did you bed-make?’
 ~‘Did you make your bed?’
- b. Har du [$\underset{\cdot}{\circ}$ redt] [$\underset{\cdot}{\circ}$ din $\overset{\cdot}{\circ}$ seng]?
 Have you made your bed
 ‘Did you make your bed?’
- c. Har du [$\underset{\cdot}{\circ}$ redt] [$\underset{\cdot}{\circ}$ seng.en]?
 Have you made bed.DEF
 ‘Did you make the bed?’

There are two things to note here. First, the main purpose of the prosodic bracketing is to show that in the SNI cases, (1a) and (2a), the verb and its object are part of the same phonological phrase, whereas

²We use ‘~’ to indicate closest idiomatic English translation, ‘*’ for syntactic ungrammaticality, ‘#’ for pragmatic anomaly, ‘=’ for possible interpretation, and ‘≠’ for impossible interpretation.

in the other cases they are in separate phrases. Second, the semantic differences between the (a) and (b) sentences do not readily translate into English. We have attempted to indicate the relevant distinctions by giving two translations for the (a) cases. We return to this in more detail in section 1.2.3 below.

1.2.1 Phonology

The standard phonological characterization of Danish SNI is in terms of “unit accentuation” (Jespersen, 1934; Rischel, 1983). As the term indicates, the verb and its incorporated element form a single stress group, whose main stress falls on the incorporated noun. We analyze this property as the result of phonological phrasing and concomitant destressing of the verb. The exact degree of stress loss, and the number of stress levels in Danish generally, has been extensively debated in the literature (Fischer-Jørgensen, 1983; Basbøll, 1995); we remain agnostic about these issues here.

One further complication is due to contrastive stress, which may override the normal SNI destressing of the verb:

- (3) A: Købte Peter 'hus sidste år?
 B: Nej, han 'solgte 'hus sidste år.
 A: ‘Did Peter buy a house last year?’
 B: ‘No, he **sold** a house last year.’

In this example, the contrastive stress on *solgte* obscures the normal SNI destressing. As (3A) shows, the verb can be nonadjacent to its incorporated object; this is further discussed in the next section.

1.2.2 Syntax

There are three essential syntactic properties of SNI. First, in contrast to morphological incorporation, the incorporated element is a phrase, not a word. In particular, we argue that it is a special kind of unsaturated noun phrase (of the type *lite*; Abeillé and Godard 2000). Second, there is no adjacency requirement on the linearization of the verb and the incorporated phrase. Third, the incorporated object reduces the valence of the verb by saturating an argument position.

That the incorporated element is a phrase and not a word is supported by the fact that it can take adjectival modification and can be a conjunction:

- (4) a. Min nabo [p købte 'nyt 'hus] sidste år.
 My neighbour bought new house last year
 b. Min nabo [p købte (både) 'hus og 'bil] sidste år.
 My neighbour bought (both) house and car last year

However, the incorporated element cannot be a full noun phrase. In particular, it may not contain a specifier (article, numeral, or quantifier) or a relative clause (restrictive or nonrestrictive, extraposed or not):³

- (5) a. *Min nabo [_p købte et 'hus / hus.et / to
My neighbour bought a house / house.DEF / two
hus.e / nogle hus.e] sidste år.
house.PLU / some house.PLU last year
- b. *Min nabo [_p købte 'hus som kostede over en
My neighbour bought house which cost over one
million] sidste år.
million last year
- c. *Min nabo [_p købte 'hus] sidste år som
My neighbour bought house last year which
kostede over en million.
cost over one million

There are two qualifications to this characterization of incorporable noun phrases. Modification of plural nouns is usually better; this may be related to the fact that bare plurals are generally possible. Also, adjectival modification is only allowed insofar as it does not interfere with the pragmatic restriction on the institutionalized interpretation of the SNI construction (see section 1.2.4).

The second syntactic characteristic also sets SNI apart from morphological incorporation: adjacency of the verb and the incorporated element is neither necessary nor sufficient for SNI. Nonadjacency occurs in interrogative subject verb inversion (see example (3A) above) and when adverbials intervene between the verb and the incorporated element, as in the following example (Herslund, 1997, (10d)).

- (6) Julie [_p læser 'fandeme også 'altid 'amerikanske 'tegneserier].
Julie reads bloody also always American cartoons
'Julie always freakin' reads American cartoons.'

And, even when adjacency is respected, a noun carrying the definite suffix cannot be incorporated:

- (7) *Min nabo [_p købte 'huset] sidste år.
My neighbour bought house-DEF last year

³The status of other postnominal modifiers and complements is not entirely clear, so we leave them aside here.

Finally, the incorporated object saturates an argument slot of the verb, such that the result of incorporating an object cannot take another object argument:

- (8) * Min nabo [_p købte 'hus] villa sidste år.
My neighbour bought house-DEF villa last year

A transitive verb like *købte* is thus detransitivized and acts as an intransitive. This latter property holds for compounding, but not classificatory, morphological incorporation (Gerds, 1998, 88–89).

1.2.3 Semantics

The basic characterization of the semantics of SNI, going back to Jespersen (1934), is that the resulting, complex predicate has “semantic and conceptual unity” (Nedergaard Thomsen, 1995, 151). The incorporated nominal also has a different (more restricted) semantics than an unincorporated object.

First, the incorporated nominal is interpreted as nonspecific in reference. As indicated by the data in (9), the incorporated element must take narrow scope with respect to the intensional verb.

- (9) Min bror vil gerne [_p købe 'hus].
My brother will PARTICLE buy house
=‘My brother wants to buy a house (any house).’
≠‘There is a house that my brother wants to buy.’

Although, we do not equate specificity with wide scope, we do believe that the *consistent* narrow scope readings of incorporated objects indicate that they are nonspecific (see Van Geenhoven 1998 for this and related tests).⁴

1.2.4 Pragmatics

One commonly discussed pragmatic restriction on SNI is that the resulting predicate must denote an action that is “institutionalized” (Rischel,

⁴However, conversational implicature may give rise to a specific reading in certain cases. This is exemplified in (1), where the question is normally taken as asking whether the addressee made his/her own bed.

- (1) Har du [_p redt 'seng]?
Have you made bed
‘Did you bed-make?’

It is possible to think of situations where this implicature does not hold. For example, if (1) is part of a checklist for a practical exam for hospital orderlies, the question would only be asking whether the orderly made a bed, as per the exam requirements. There would be no implicature that it is the orderly’s own bed.

1983). In other words, the denotation of the incorporated verb phrase must be an action or event which is conventionally associated with a certain structure or set of activities. A similar point is made by Mithun (1984, 848), with respect to morphological incorporation. Contrast (1a) above with (10) below.⁵

- (10) # Min nabo [_p købte 'blyant] igår.
My neighbour bought pencil yesterday

Furthermore, the incorporated object has different discourse anaphoric properties from an unincorporated object. First, the incorporated element cannot be anaphorically dependent on a preceding NP:

- (11) Jeg [_p skrev 'brev_i] til Pia og idag [_p fik hun 'brev_{*i/j}].
I wrote letter to Pia and today got she letter
~‘I wrote a letter to Pia and today she got (another) letter.’

This has not been observed in the literature on SNI, but has been noted for morphological incorporation in West Greenlandic (Bittner, 1994).

Second, incorporated noun phrases generally do not license discourse anaphora (i.e. no subsequent pronominal can be anaphorically dependent on the incorporated element). However, as illustrated in (12), there is lexical variation with regard to this.

- (12) a. Vita [_p købte 'hus_i] sidste år. Det_i ligger i Hals.
Vita bought house_i last year. It_i lies in Hals.
~‘Vita bought a house last year. It is in Hals.’
b. Rikke forsøgte [_p at rede 'hår_i]. ?# Det_i var helt filtret
Rikke tried to comb hair_i. It_i was all tangled
after cykelturen.
after bike.ride.DEF
~‘Rikke tried to comb her hair. It was all tangled up after the bike ride.’
c. Mikkel [_p holdt 'forelæsning_i]. # Den_i var spændende.
Mikkel held lecture_i. It_i was interesting.

⁵A reviewer provided examples (a) and (b) to show that similar pragmatic restrictions hold for bare nominal complements of prepositions in English; note the contrast with (c):

- (1) a. Mary stayed in bed. (usual activity, sleeping, etc.)
b. Mary stayed in the bed. (hiding during hide and seek)
c. Mary stayed in *(the) room.

Danish shows a similar contrast for prepositional complements, but we have not investigated these (or the English examples) and their relation to SNI systematically.

We think this phenomenon is comparable to what we call inferential pronominalization, where there is no overt antecedent for the pronoun:

- (13) a. Peter got married last July. She’s an architect.
 b. # Peter got adopted last July. She’s an architect.

Similarly to the SNI cases in (12), the possibility of inferential pronominalization in the English examples above depends on lexical factors. Although we can reasonably infer a female participant in both marriage and adoption, only the first sentence is felicitous.

We conclude that syntactically incorporated nominals in Danish do not license discourse anaphora. This sets SNI apart from the kind of morphological incorporation found in West Greenlandic, where incorporated nominals do license discourse anaphors, as argued by Van Geenhoven (1998, 47-9).

In our HPSG analysis, we do not attempt to directly account for these discourse properties. We think that these phenomena are best handled in a dynamic semantic framework, perhaps along the lines of Van Geenhoven (1998). Note that the lack of discourse transparency in SNI is consistent with the impossibility of the incorporated element heading a relative clause, in which the relative pronoun is anaphorically dependent on the head of the relative clause.

1.3 Danish SNI in the typology of incorporation

As discussed throughout the previous section, Danish SNI shares a number of characteristics with type I incorporation (sample languages given below) in Mithun’s (1984) typology:

1. The incorporated nominal is interpreted non-specifically.
2. The resulting predicate must denote an institutionalized activity.
3. Incorporated nominals do not have a determiner.
4. The incorporated nominal must be a patient, location or instrument argument of the incorporating verb.⁶

What sets Danish apart from other type I incorporating languages is the way the incorporation is expressed. The closest analog to SNI is “omposition by juxtaposition”, which is found, for example, in certain Oceanic (e.g. Mokilese, Yapese, and Samoan) and Mayan (e.g. Mam, Kanjobal) languages (Mithun, 1984, 849–853). In this kind of incorporation construction the verb and the incorporated nominal are juxtaposed

⁶In Danish, only patients/themes can incorporate. For reasons of space, we have not discussed this specific property, but it holds in all the examples given and is further supported by the incorporation of arguments of unaccusatives in intransitive expletive sentences.

but remain phonologically separate units, whereas in Danish the verb and its incorporated nominal form a single phonological unit. Also, in certain cases modifiers to the verb or the noun may intervene between the verb and the incorporated nominal (see section 1.2.2).

1.4 Formal analysis

Following Abeillé and Godard (2000, 334), we use a multiple-inheritance type hierarchy to cross-classify the type *sign* for weight and phrasality.⁷

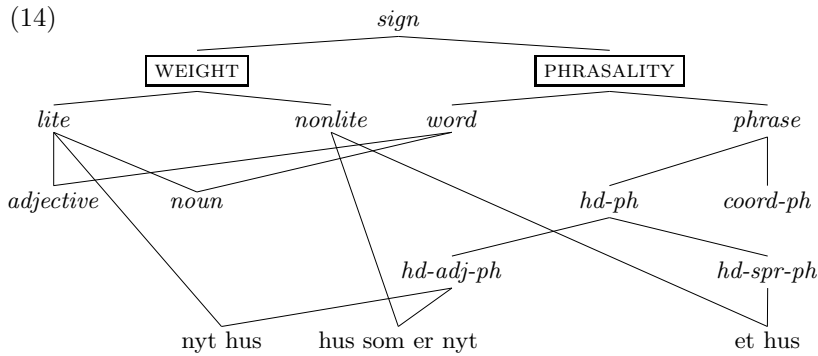

Adjectives and common nouns are specified as *lite* in the lexicon. Clausal postnominal modifiers are *nonlite*. Phrases of type *hd-adj-ph* and *coord-ph* inherit their weight values from their daughters in the following manner (adapted from Abeillé and Godard 2000, 333):

- (15) a.
$$\left[\begin{array}{ll} \textit{head-adjunct-phrase} \wedge \textit{lite} & \\ \text{HEAD-DAUGHTER} & \textit{lite} \\ \text{NON-HEAD-DAUGHTERS} & \langle [\textit{lite}] \rangle \end{array} \right]$$
- b.
$$\left[\begin{array}{ll} \textit{coordinated-phrase} \wedge \textit{lite} & \\ \text{NON-HEAD-DAUGHTERS} & \textit{list}(\textit{lite}) \end{array} \right]$$

The constraints are stated in such a way that these phrases are *lite* if and only if all of their daughters are *lite*. In other words, conjoined noun phrases are *lite* iff both conjuncts are *lite*, and head-modifier phrases are *lite* iff the modifier is *lite* (the head noun is lexically specified as *lite*; see (14) above). Since relative clauses are *nonlite*, noun phrases containing a relative clause will never be *lite*. Together with the restriction

⁷Abeillé and Godard (2000) introduce the term ‘weight’ to characterize a property of linguistic expressions (words and phrases) that influences both word order (e.g. *lite* elements must precede *nonlite* elements within a certain domain) and combinatorial syntax (e.g. a *lite* modifier may only combine with a *lite* head).

that incorporated elements must be *lite*, introduced in (16) below, this accounts for the ban on relative clauses in SNI.

We use a description level lexical rule (DLLR) (Meurers, 1995, 1999) to state the lexical relationship between normal transitive verbs and SNI verbs. For readability, we further articulate the structure of the incorporated element — the value of RESULT|SS|LOC|CAT|COMPS — in (18) below.

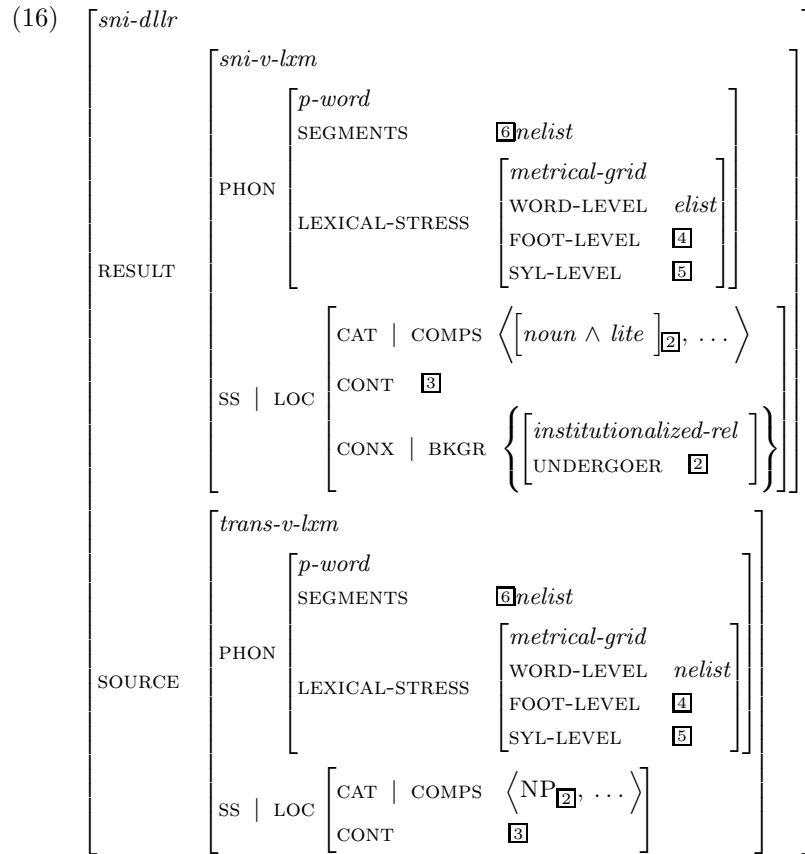

This captures three of the SNI facts lexically, but before discussing these we have to explain our extensions to the PHONOLOGY feature. Following the string-based approach of Bird and Klein (1994, 62) and Monachesi (1999, 72), we assume the partition for *phon* to be:

$$(17) \quad \text{phon} \rightarrow \text{utterance} \vee \text{p-phrase} \vee \text{p-word} \vee \text{foot} \vee \text{syl(lable)} \vee \text{segment}$$

One of the features appropriate for *phon* is SEGMENTS, with the value *list(segments)*. The SEGMENTS value of a *syllable* is a list of *segment* objects representing the segments that make up the syllable being modelled. Similarly, the SEGMENTS value of a *foot* is a list of *segment* objects representing the segments that make up the foot in question. To ensure that the linear order of SEGMENTS is preserved when building larger phonological constituents out of smaller ones, we use the list append operator, \oplus , such that the SEGMENTS list of a *foot* is the append of the SEGMENTS lists of the *syllable* objects that make up that foot, and so on.

The feature LEXICAL-STRESS is declared for objects of type *p-word*. Its value is an object of type *metrical-grid*, which encodes stress placement up to the level of the phonological word, according to the grid representation proposed for metrical phonology (Lieberman and Prince, 1977; Hayes, 1995). The value of each of the three features SYL-LEVEL, FOOT-LEVEL, and WORD-LEVEL is *list(syl)*. For each of these features, if a syllable is present on the feature's list value, it bears stress at that level. If a syllable is on the WORD-LEVEL list, it must also be on the FOOT-LEVEL list, and if it is on the FOOT-LEVEL list, it must be on the SYL-LEVEL list (cf. the 'Continuous Column Constraint' of Hayes 1995, 34). This can be formalized with a pair of implicational constraints.

We can now return to three SNI facts captured by (16). First, the stress reduction on the verb is indicated in the value of the feature LEXICAL-STRESS. Since the SNI verb is unstressed at the word level, the rule indicates that its WORD-LEVEL feature is an empty list. As indicated by coindexing the values in SOURCE and RESULT, the foot and syllable level stress remain the same (see Fischer-Jørgensen 1983).

Second, we introduce a new kind of relation, *institutionalized-rel*, to capture the pragmatic restrictions on SNI discussed above. Since the 'institutionalized reference' restriction never applies to the subject (i.e. the subject is free to vary), the restriction must be imposed only on the verb plus its incorporated, direct object. We achieve the required effect by coindexing the incorporated object with the UNDERGOER of the *institutionalized-rel*, which is in the BACKGROUND of the incorporating verb's CONTEXT. The pragmatic restriction can then apply such that the incorporated nominal must be participating in some kind of institutionalized activity, as required.

Third, the DLLR in (16) captures the special subcategorization requirements of incorporating verbs, namely that the incorporated nominal must be of type *lite*. Furthermore, we propose that nonspecific reference of the incorporated nominal arises as a consequence of the nominal being both *lite* and predicative, as illustrated in (18).

$$(18) \left[\begin{array}{l} \textit{lite} \wedge \textit{noun} \\ \text{CAT} \left[\begin{array}{l} \text{HEAD} \left[\text{PRD} \quad + \right] \\ \text{SPR} \quad \langle [] \rangle \end{array} \right] \\ \text{CONT} \left[\begin{array}{l} \textit{content} \\ \text{SPECIFIC} \quad - \\ \text{INDEX} \quad \textit{ref} \end{array} \right] \end{array} \right]$$

This move is supported by the occurrence of *lite* predicative nouns in other syntactic configurations in Danish. For example, nominal complements of copulas and predicative nominals in resultative constructions are never specific in reference.

- (19) a. Hun er lærer.
 She is teacher.
 ‘She is a teacher.’
- b. Han blev valgt til president.
 He was elected to president.
 ‘He was elected president.’

It is important to note that using description level lexical rules in this manner will allow the standard linearization principles of Danish to apply. In particular, subject verb inversion in interrogatives and adverb placement will occur as usual (Hentze, 1996).

To account for the conditions on phonological phrasing, we propose a general mechanism for calculating phrasing in parallel with syntactic combination. Using the value of the SEGMENTS feature for individual words, we augment the combinatorial schemas to add phrasing information to the SEGMENTS value of phrasal categories. Crucially, words do not have phrasing information. We introduce the special boundary segments ‘[’ and ‘]’. Although these will be on the SEGMENTS list, they are in effect the phonological representation of pauses, and are not phonemes. Prosodic bracketing will allow domain restrictions on certain phonological processes to be stated directly on the SEGMENTS list. Asudeh (1999) provides preliminary experimental evidence for one such process, namely lengthening of the final rhyme before a phonological phrasing boundary.

For purposes of illustration, consider the augmented *hd-comp-ph* schema in (20), based on Sag (1997).

$$(20) \left[\begin{array}{l} \textit{hd-comp-ph} \\ \text{PHON | SEGMENTS } \langle [] \oplus \boxed{1} \oplus \boxed{2} \oplus \dots \oplus \boxed{n} \oplus [] \rangle \\ \text{COMPS } \langle \rangle \\ \text{HD-DTR } \left[\begin{array}{l} \text{PHON | SEGMENTS } \boxed{1} \\ \text{COMPS } \langle \boxed{3}, \dots, \boxed{m} \rangle \end{array} \right] \\ \text{NON-HD-DTRS } \left\langle \left[\begin{array}{l} \text{PHON | SEGS } \boxed{2} \\ \text{SYNSEM } \boxed{3} \end{array} \right], \dots, \left[\begin{array}{l} \text{PHON | SEGS } \boxed{n} \\ \text{SYNSEM } \boxed{m} \end{array} \right] \right\rangle \end{array} \right]$$

The effect of the segment concatenation operation, represented by the infix \oplus operator is illustrated in (21) below. Crucially, we assume that the various schemas differ in how they affect phonological phrasing. In particular, *hd-subj-ph*, *hd-spr-ph*, and *hd-comp-ph* introduce bracketing, whereas *hd-adj-ph* does not introduce bracketing:

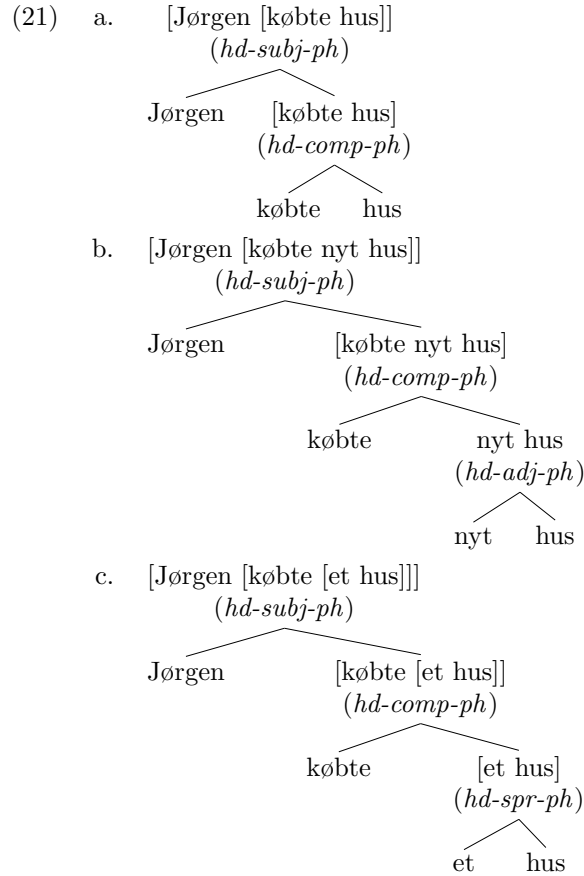

That phrasal types may affect phonological phrasing differently is a hypothesis that is motivated by the SNI data. Ultimately, we hope to find further, independent support for this hypothesis. One important factor that we have not said anything about is the effect of focus, and more generally information structure, on phonological phrasing.

1.5 Conclusion

In this paper, we have presented a formal treatment of grammatical interfaces using description level lexical rules in the lexicon and phonologically augmented constraints on phrasal types in the syntax. The empirical motivation for this analysis came from syntactic noun incorporation in Danish, but we believe the core ideas can be extended to other domains. Throughout, the lexicon and syntax have played a crucial role in tying together the restrictions on SNI in various grammatical domains. The analysis shows how Abeillé and Godard's *lite/nonlite* distinction is relevant for Danish and how cross-classification of types (Flickinger et al., 1985) is necessary to capture the correct restrictions on the nominal elements that may incorporate in Danish (i.e. the incorporated element can be a word or a phrase, as long as it is *lite*).

We have extended the HPSG treatment of phonology to deal with (word) stress and phrasing, though the relationship between the two remains an empirical question and we leave its investigation for future research. Our analysis shows how phonological phrasing can be built up in parallel with syntactic combination. This is in line with recent proposals by Steedman (2000), who argues for a syntax-prosody isomorphism, and Truckenbrodt (1999), who argues for a constraint-governed syntax-prosody mapping.

However, our parallel approach is distinct from both of these other approaches. Unlike Steedman, we do not posit that phonological phrasing is isomorphic to syntactic structure. Although we build up the two in parallel, using the standard combinatorics of HPSG, we allow for other constraints concerning information structure and postlexical accent placement to affect phrasing. The parallel approach is also different from Truckenbrodt's mapping approach, where syntax and phonology are built up independently and are then related in an Optimality Theory constraint interaction.

Our approach to the syntax-prosody interface is compatible with the core HPSG notion of parallelism in information encoding. The bracketing conventions introduced may also serve to state domain restrictions on phonological processes, such as assimilation, deletion, final lengthening, etc.

The representation we use for phonological phrasing has a number of properties that we summarize here. First, we use brackets, rather than boundary symbols, committing us to a constituency rather than boundary segment approach (Hayes, 1989). Second, we allow for recursive phonological structure, since phrasing is built up in parallel with the syntax, which is recursive (see the trees in (21) above). Since our brackets are unlabelled, this does not violate Strict Layering (Selkirk, 1984), which postulates that a phonological constituent cannot contain a phonological constituent of the same kind. We do not have ‘kinds’ of phonological constituents, so our representations satisfy this requirement vacuously, despite being recursive.

References

- Abeillé, A. and D. Godard. 2000. French word order and lexical weight. In R. D. Borsley, ed., *The Nature and Function of Syntactic Categories*, pages 325–360. New York: Academic Press.
- Asudeh, A. 1999. Intonation as a disambiguation strategy in Danish. Ms., Stanford Linguistics Department.
- Basbøll, H. 1995. Degrees of stress in Modern Danish: Primary, secondary and tertiary. In Rischel and Basbøll (1995), pages 21–47.
- Bird, S. and E. Klein. 1994. Phonological analysis in typed feature systems. *Computational Linguistics* 20:55–90.
- Bittner, M. 1994. *Case, Scope and Binding*. Dordrecht: Kluwer.
- Fischer-Jørgensen, E. 1983. The acoustic manifestation of stress in Danish with particular reference to the reduction of stress in compounds. In M. van den Broeke, V. van Heuven, and W. Zonneveld, eds., *Sound Structures. Studies for Antonie Cohen*, pages 81–104. Dordrecht: Foris.
- Flickinger, D., C. Pollard, and T. Wasow. 1985. Structure-sharing in lexical representation. In *Proceedings of the 23rd Annual Meeting of the Association for Computational Linguistics*.
- Gerdtz, D. B. 1998. Incorporation. In A. Spencer and A. Zwicky, eds., *The Handbook of Morphology*, pages 84–100. Oxford: Blackwell.
- Hayes, B. 1989. The prosodic hierarchy in meter. In P. Kiparsky and G. Youmans, eds., *Rhythm and Meter*, vol. 1 of *Phonetics and Phonology*. New York: Academic Press.
- Hayes, B. 1995. *Metrical Stress Theory: Principles and Case Studies*. Chicago: University of Chicago Press.
- Hentze, R. 1996. *Unit Accentuation in a Topological Grammar of Danish: A Constraint-Based Approach*. Master’s thesis, University of Copenhagen.

- Herslund, M. 1997. The object relation and the notion of incorporation. In L. Schøsler and S. Kirchmeier-Andersen, eds., *Studies in Valency II: The Pronominal Approach Applied to Danish*. Odense: Odense University Press.
- Jespersen, O. 1934. *Modermaalets fonetik*. Copenhagen: Nordisk Forlag. Reprinted 1949.
- Lieberman, M. and A. Prince. 1977. On stress and linguistic rhythm. *Linguistic Inquiry* 8:249–336.
- Meurers, W. D. 1995. Towards a semantics for lexical rules as used in HPSG. Revised version of the paper presented at the Conference on Formal Grammar, 1995, Barcelona.
- Meurers, W. D. 1999. *Lexical Generalizations in the Syntax of German Non-Finite Constructions*. Ph.D. thesis, Seminar für Sprachwissenschaft, Universität Tübingen, Tübingen, Germany. Volume 145 in Arbeitspapiere des SFB 340.
- Mithun, M. 1984. The evolution of noun incorporation. *Language* 60:847–894.
- Monachesi, P. 1999. *A Lexical Approach to Italian Cliticization*. Stanford, CA: CSLI Publications.
- Nedergaard Thomsen, O. 1992. Unit accentuation as an expression device for predicate formation. The case of syntactic noun incorporation in Danish. In M. Fortescue, P. Harder, and L. Kristoffersen, eds., *Layered Structure and Reference in a Functional Perspective*, pages 173–229. Amsterdam: John Benjamins.
- Nedergaard Thomsen, O. 1995. Discourse, grammar, and prosody in a corpus of spoken Danish — a functional pragmatic account. In Rischel and Basbøll (1995), pages 129–213.
- Rischel, J. 1983. On unit accentuation in Danish – and the distinction between deep and surface phonology. *Folia Linguistica* 17:51–97.
- Rischel, J. and H. Basbøll, eds. 1995. *Aspects of Danish Prosody*. Odense: Odense University Press.
- Sag, I. A. 1997. English relative clause constructions. *Journal of Linguistics* 33:431 – 483.
- Selkirk, E. 1984. *Phonology and Syntax*. Cambridge, MA: MIT Press.
- Steedman, M. 2000. Information structure and the syntax-phonology interface. *Linguistic Inquiry* 31(4).
- Truckenbrodt, H. 1999. On the relation between syntactic phrases and phonological phrases. *Linguistic Inquiry* 30(2):219–255.
- Van Geenhoven, V. 1998. *Semantic Incorporation and Indefinite Descriptions: Semantic and Syntactic Aspects of Noun Incorporation in West Greenlandic*. Stanford, CA: CSLI Publications.