

Energy from Biomass



Energy_from_Biomass

Agenda

- World biomass inventory
 - Global challenges: Tree losses, deforestation of tropical/rainl forests
- Biomass energy resources, farming and harvesting
 - Renewable biomass principle,
 - US geographical bio-energy farming areas
 - Biomass energy density, heating value, GHG emission
- Biomass-Energy conversion methods
 - Direct combustion
 - Biomass to gas and liquid, ethanol production
 - pyrolysis, Fischer-Tropsch process
- Current biomass utilization
 - Transportation fuels, ethanol, biodiesel
 - Share in total electricity generation
- Strategic Issues biomass utilization

Photosynthesis

Oxygenic photosynthesis = main source of oxygen in atmosphere;
Water donates electron and is oxidized to O_2 .



Photosynthesis: photochemical + biochemical (endoenergetic) reaction, needs $2(h\nu = 1.9eV, \lambda = 0.7\mu)$

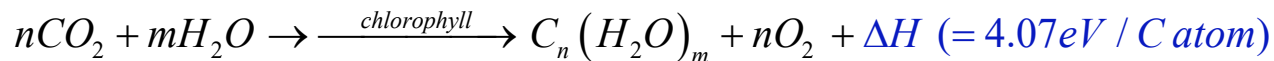

$C_n(H_2O)_m = \text{carbohydrate sugar, starch, cellulose (mostly : } n \approx m)$

World Biomass Energy Resources/Prospects



Living mass (total)	2	Tt	World population	8.2	B	↗
Land plants	1.8	Tt	Per capita plant biomass	0.3	kt/p	↘
Forests	1.6	Tt	Energy gained in biomass	$3 \cdot 10^{21}$	J/a	
Net annual production	0.4	Tt/a	Biomass energy consumption	$6 \cdot 10^{19}$	J/a	
Energy stored in biomass	$2.5 \cdot 10^{22}$	J	Food energy consumption	$2 \cdot 10^{19}$	J/a	

Biomass energy gained $30 \cdot 10^{20}$ J/a → Biomass energy consumed $\sim 10^{20}$ J/a

Sustainable at present few-% levels. But avoid substantial consumption increases → O₂- Atmosphere!

Example Indonesia: Deforestation for Biofuels

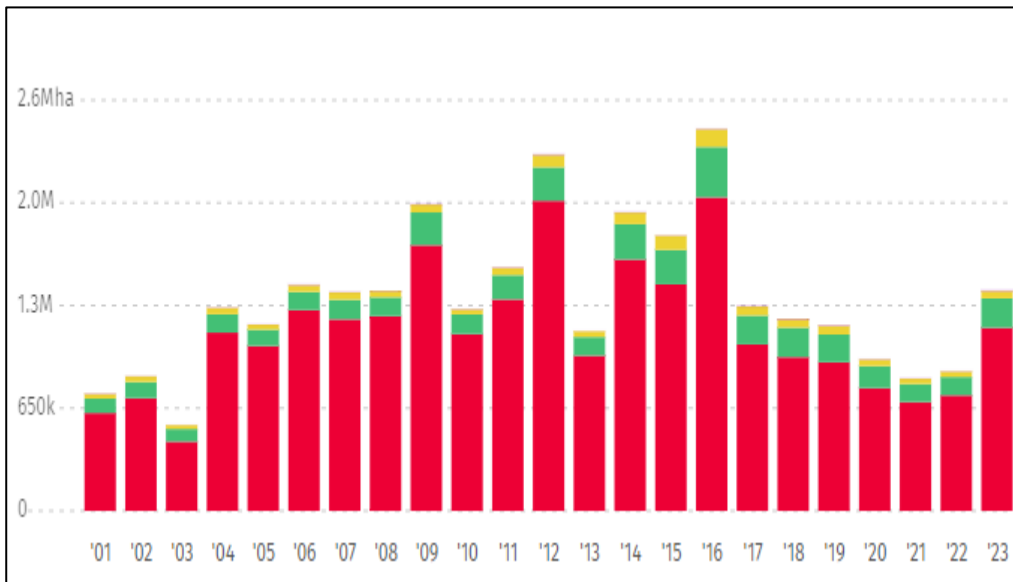

Tree Losses	1.16 Mha
Forestry	186.0 kha
Agriculture	45.8 kha
Urbanization	3.8 kha
Commodity (Plant Oil Prod)	1,160.0 kha

Example Deforestation in Brazil



Tropical forests
2% of surface.

2017:
lost $15.8 \cdot 10^6$ ha
of tropical
forests.
Humans have
destroyed $\frac{1}{2}$ of
original forest
cover.

2020 -2021: Brazilian **rainforest lost 10,476 square kilometers** – an area 13 times the size of New York City (*Imazon*, a Brazilian research institute).

Every year: Earth loses tropical forestland = size of Bangladesh (Global Forest Watch).

Related: “Rental” of Argentina’s former forest areas for soy oil production.

World Biomass Losses

Tree Losses	2001-2020
Canada	57.5 Mha
United States	47.9 Mha
Indonesia	30.8 Mha
DRC Congo	19.7 Mha
China	12.1 Mha

Drivers

Wildfires

Forestry

Agriculture

Urbanization

Commodity

<https://www.globalforestwatch.org/dashboards/country/IDN/?category=forest-change>

Renewable Biomass Energy: Principle

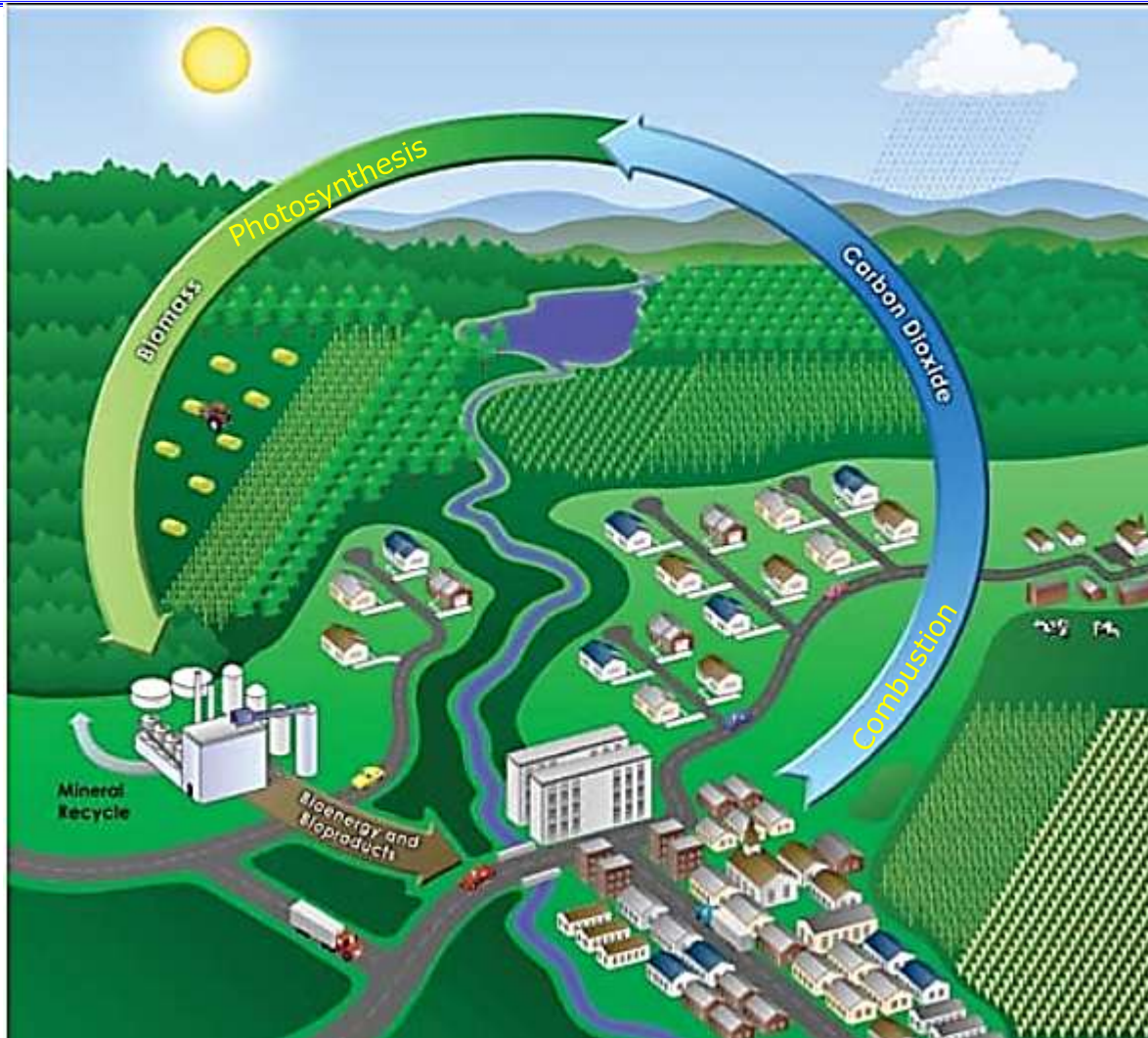

Sustainable use of ethanol from cellulosic biomass could reduce emissions of greenhouse gases (CO_2).

Dedicated "fuel plantations": Photosynthetic production of new biomass takes up some of the carbon dioxide released in combustion of biofuel (bioethanol), not all.

Task of scalability:
Grow biomass as fast as it is burned!

www.ornl.gov/info/ornlreview/v33_2_00/bioenergy.htm

Harvesting Bio-Energy

Principle: Capture energy carrying carbohydrates from plants → combust fuel (directly or after refining).

1) Grow annual energy crops: corn (maiz), rape soybean, sugar cane,..., algae.

Competes with food production/food chain

2) Harvest fast-growing trees, underbrush, grasses, oil palms

Compromises soil, natural forest/habitat, lessens CO₂ sequester.

3) Collect organic waste (→Combustion)

Rural Resources:

Forest residues and wood (mill, saw)wastes

Crop residues

Manure biogas

Urban Resources:

Urban wood waste

Land fill gas (LFG)

Wastewater treatment biogas

Food processing residue

No known negative side-effects.



Switchgrass



U.S. Bio-Energy Generation

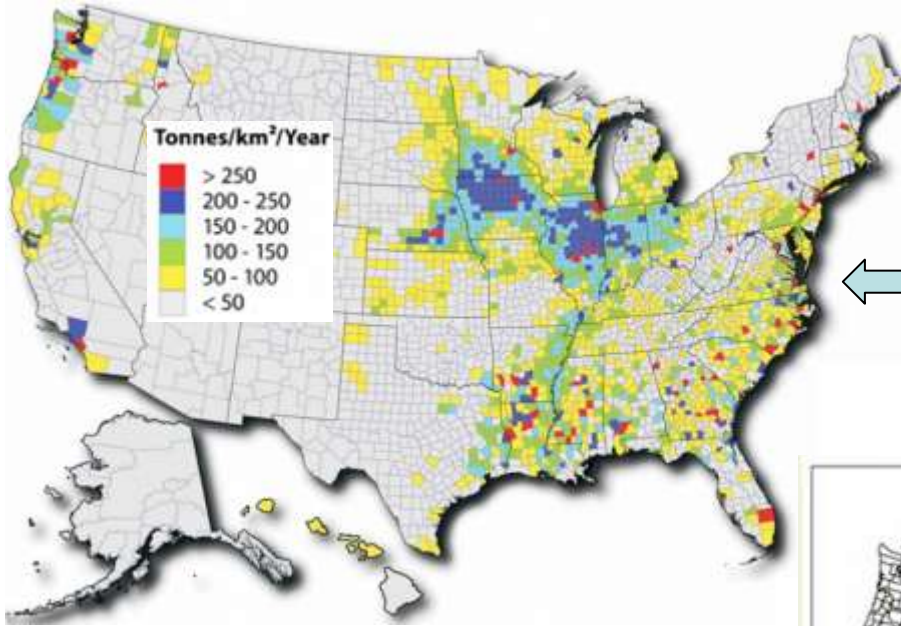

Biomass feedstock categories:
crop residues (average 2003-2007),
forest and primary mill residues,
secondary mill and urban wood waste,
biogas (methane) from landfills,
domestic wastewater treatment,
animal manure.

<http://www.nrel.gov/docs/fy06osti/39181.pdf>.

US: Corn grain monoculture used to produce feedstock for liquid transportation fuel (bio-ethanol, -diesel).

→ Midwest biomass power plants located near agricultural areas →

→ Prairie lands for future switch grass harvesting ? (GW Bush adm)

Strong agriculture lobby → subsidies (farm bill, industrial agr.)

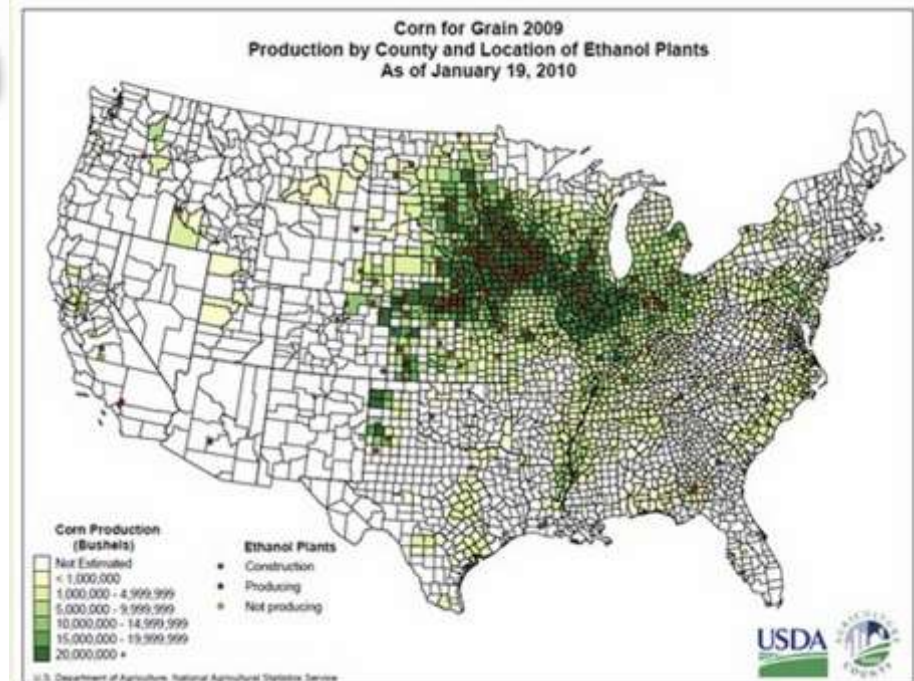

Bio-Energy Crops Energy/Power Density

Energy_from_Biomass

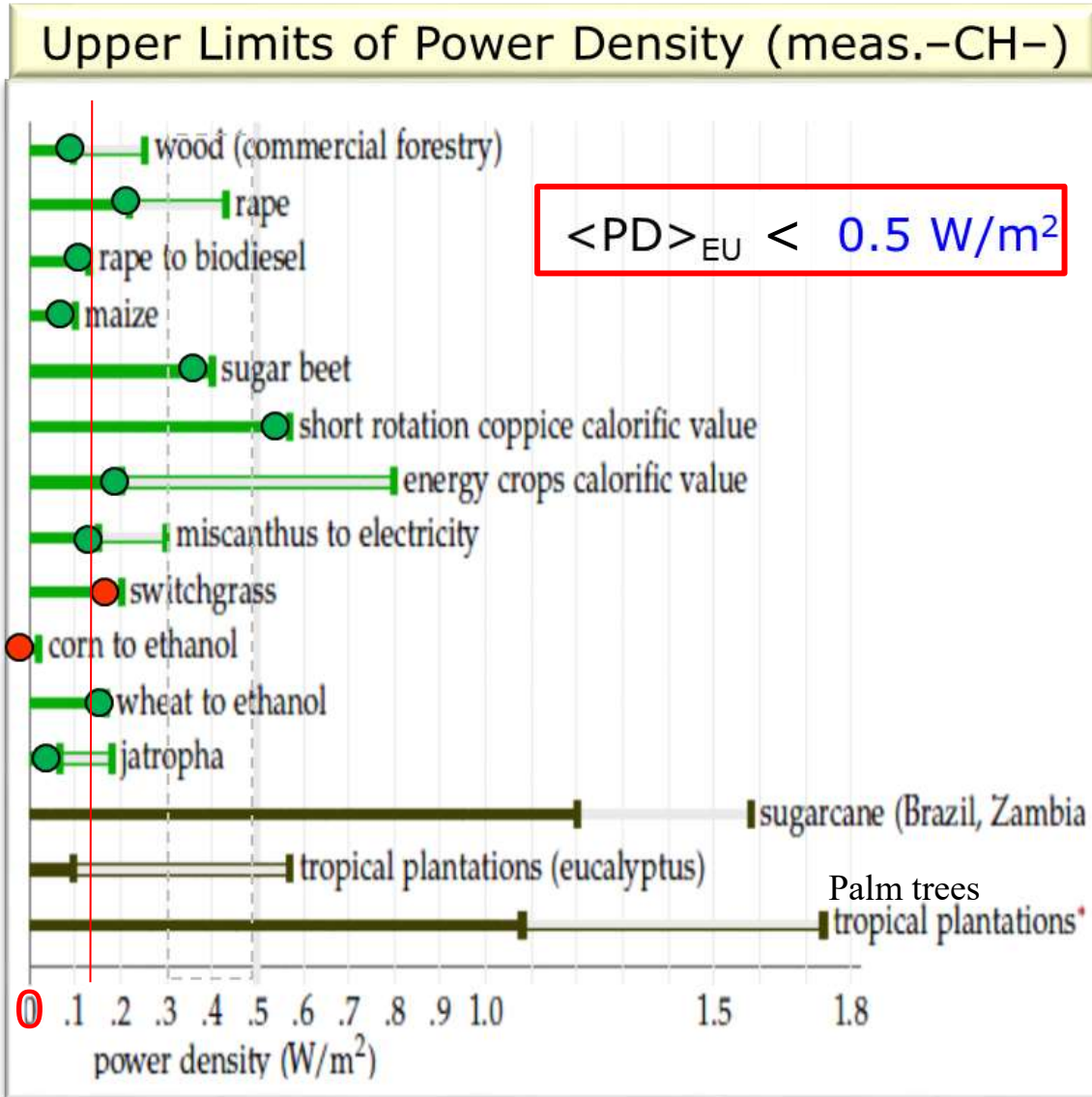

U.S. arable land $\approx 18\%$ of total (0.5 ha = 5,000 m²/cap).
(World Bank report, 2010)

Quantitative studies:
EU > 5 kW/cap;
U.S. > 10 kW/cap
continuous. (MacKay, Slim,
The Economist)



Chris Hallman/University Photography
Ecologist David Pimentel, shown here pumping gas, says that his analysis shows that producing ethanol uses more energy than the resulting fuel generates.

Fuel Energy Density

Competitive cost of biomass < \$ 3/GJ.
 McNeil Power Station (VT) burns wood for \$11-\$25.3/1000 "green kg"
 (\$(10-23)/ton, delivered (~\$(20-46)/dry ton)
 or (~\$(1.2-2.7)/million Btu).

➔ US & EU subsidize price.

Storage material	Energy type	MJ per kilogram	MJ per liter (l)
Deuterium-tritium	Nuclear fusion	330 000 000	6 368 000 000
Uranium-235	Nuclear fission	79 500 000	1 534 000 000
Hydrogen (compressed at 700 bar)	Chemical	123	5.6
Gasoline (petrol) / Diesel	Chemical	~46	~36
Propane (including LPG)	Chemical	46.4	26
Fat (animal/vegetable)	Chemical	37	
Coal	Chemical	24	
Carbohydrates (including sugars)	Chemical	17	
Protein	Chemical	16.8	
Wood	Chemical	16.2	
TNT	Chemical	4.6	
Gunpowder	Chemical	3	
Lithium battery	Electrochemical	1.8	4.32
Lithium-ion battery	Electrochemical	0.72	0.9-2.23
Alkaline battery	Electrochemical	0.59	
Nickel-metal hydride battery	Electrochemical	0.288	0.504-1.08
Lead-acid battery	Electrochemical	0.1	
Electrostatic capacitor	Electrical	0.000036	

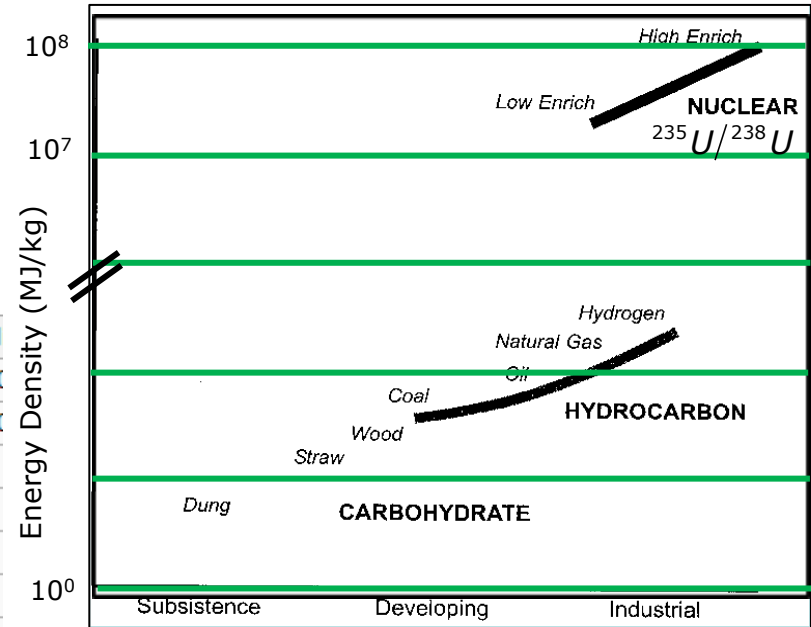

Electric power plants, home heating
Human/animal nutrition
Human/animal nutrition
Heating, outdoor cooking
Explosives
Explosives
Portable electronic devices, flashlights (non-rechargeable)
Laptop computers, mobile devices, some modern automotive engines
Portable electronic devices, flashlights
Portable electronic devices, flashlights
Automotive engine ignition
Electronic circuits

12

Energy_from_Biomass

Biofuel Properties/Emission/Ecoprint

Fuel	Net calorific value (MJ/kg)	Carbon content (%)	Approx. life cycle CO ₂ emissions (including production) See note 1		Annual total CO ₂ emissions to heat a typical house (20,000 kWh/yr)		
			kg/GJ	kg/MWh	kg	kg saved compared with oil	kg saved compared with gas
Hard coal	29	75	134	484	9680	-2680	-4280
Oil	42	85	97	350	7000	0	-1600
Natural gas	38	75	75	270	5400	1600	0
LPG	46	82	90	323	6460	540	-1060
Electricity (UK grid)	-	-	150	530	10600	-3600	-5200
Electricity (large scale wood chip combustion)	-	-	16	58	1160	5840	4240
Electricity large scale wood chip gasification)	-	-	7	25	500	6500	4900
Wood chips (25% MC) Fuel only	14	37.5	2	7	140	6860	5260
Wood chips (25% MC) Including boiler	14	37.5	5	18	500	6500	4900
Wood pellets (10% MC starting from dry wood waste) See note 3	17	45	4	15	300	6700	5100
Wood pellets (10% MC) Including boiler See note 3	17	45	7	26	660	6340	4740
Grasses/straw (15% MC)	14.5	38	1.5 to 4	5.4 to 15	108 to 300	6892 to 6700	5292 to 5100

http://www.biomassenergycentre.org.uk/portal/page?_pageid=75,163182&_dad=portal&_schema=PORTAL

Agenda

- World biomass inventory
 - Global challenges: Tree losses, deforestation of tropical/rainl forests
- Biomass energy resources, farming and harvesting
 - Renewable biomass principle,
 - US geographical bio-energy farming areas
 - Biomass energy density, heating value, GHG emission
- Biomass-Energy conversion methods
 - Direct combustion
 - Biomass to gas and liquid, ethanol production
 - pyrolysis, Fischer-Tropsch process
- Current biomass utilization
 - Transportation fuels, ethanol, biodiesel
 - Share in total electricity generation
- Strategic Issues biomass utilization

Wood Pellets for Burning/Co-Firing



Starting materials: compacted sawdust + other wastes from sawmilling and other wood products, like palm kernel shells, coconut shells, whole-tree removals, tree tops, branches left over after logging (which otherwise would help replenish soil nutrients).

Manufacturing pellets

- hammer mill produces uniform dough.
- press dough through a die with holes (6-8mm dia.)
- compressing heats pellets, lignin plasticizes = natural glue preserving pellet shape in cooling.

Europe (Germany): The MAP-program pays > € 2,000 for replacement of fossil-fuel boiler with pellet boiler, low-interest loans, 7% VAT (instead of 19%) for wood pellets.



Also in US →

2013 NEW HAMPSHIRE Wood Pellet Boiler Rebate Program
30% Rebate (with max \$6,000) in NEW HAMPSHIRE for
Whole House Wood Pellet Heating Systems

Fuel properties: Biomass contains H₂O + volatiles (aliphatic carbon atoms (open chains) + aromatic hydrocarbons (1-6 six-carbon rings characteristic of benzene series), → low efficiency in burning.

Co-firing of biomass with coal → higher overall thermal.

IEA : Capital cost of dedicated biomass plants = (3-5)x cost of co-fire plants

→ cost of electricity from coal/biomass co-firing = 50% of electricity from biomass.

Gasification/Liquefaction



Biomass-Energy Conversion Methods

1. Combustion/co-combustion → burned in boilers, furnaces, stoves, (with coal)
2. Gasification → converted to syngas (H_2 , CO ,..)
3. Liquefaction → converted to synfuel (Fischer-Tropsch)
4. Pyrolysis → thermal decomposition into gas, liquids, solids
5. Fermentation → +distillation: ethanol (C_2H_5OH), liquid fuel
6. Anaerobic digestion → mix of CO_2 , CH_4 gas, low heat value



Europe 1940s: truck fueled by “wood gas”
=(50% nitrogen, 20% carbon monoxide, 18% hydrogen, 8% carbon dioxide and 4% methane)

Biogas (CO , H_2 , CH_4) made by pyrolysis = heating of organic materials in the absence of O_2 .

Biomass to Gas and/or Liquid

Common scheme for biomass/coal gasification and subsequent liquefaction.

Fischer-Tropsch Process = catalyzed chemical reaction converting CO and H₂ (from syngas) to mix of hydrocarbons of different weights.

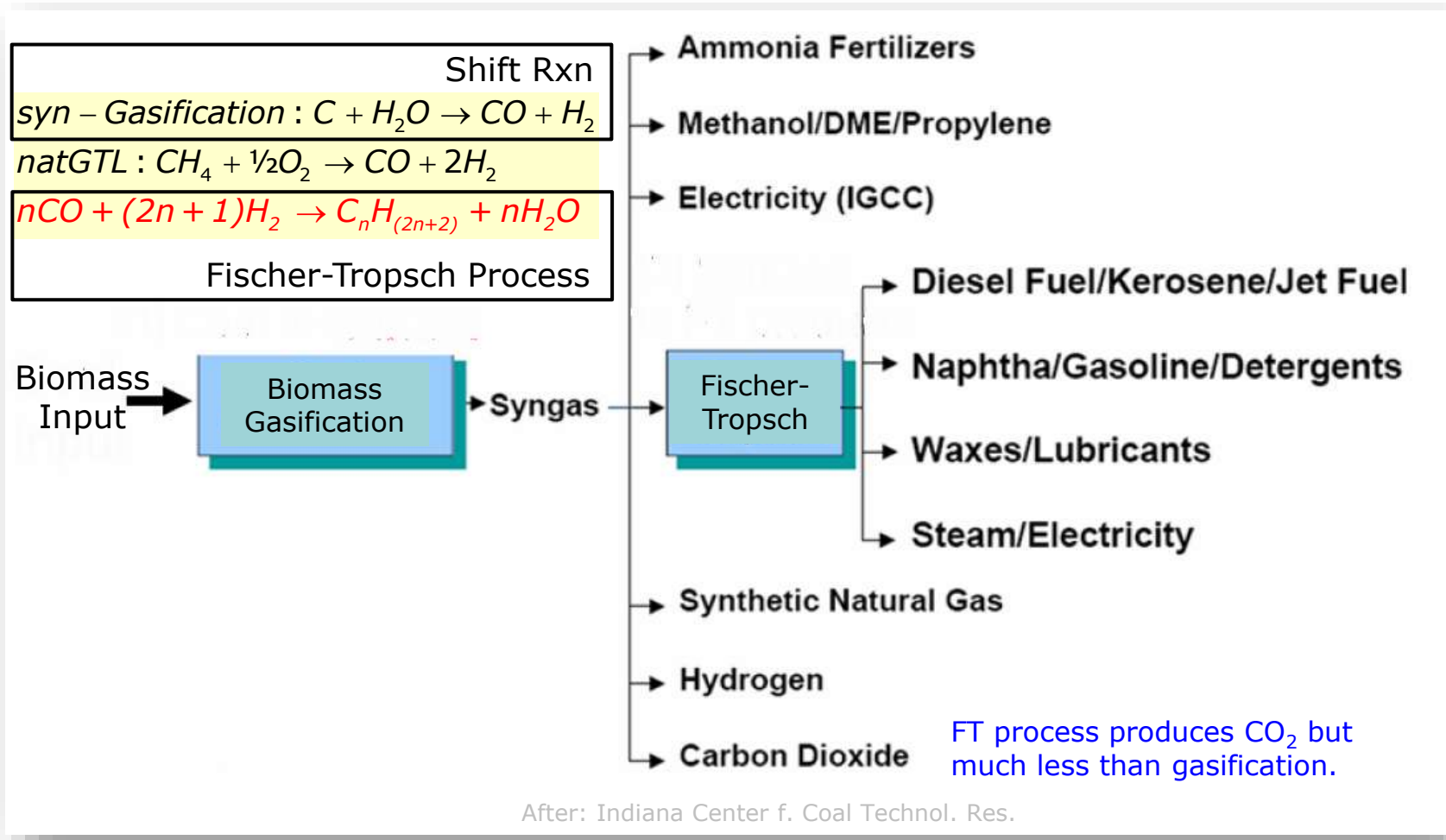

Reforming and Shift Reactions

Main high-temperature, catalytic reactions of carbon oxides, hydro-carbons with H_2O, H_2 :

Steam reforming: $C_nH_m + nH_2O \leftrightarrow (n+m/2)H_2 + nCO$ (**syngas**) endothermic, catalytic

Water-gas shift: $CO + H_2O \leftrightarrow CO_2 + H_2$, (**syngas**) exothermic, catalytic

Methanation: $CO + 3H_2 \leftrightarrow CH_4 + H_2O$, exothermic, catalytic
 $CO_2 + 4H_2 \leftrightarrow CH_4 + 2H_2O$, exothermic, catalytic

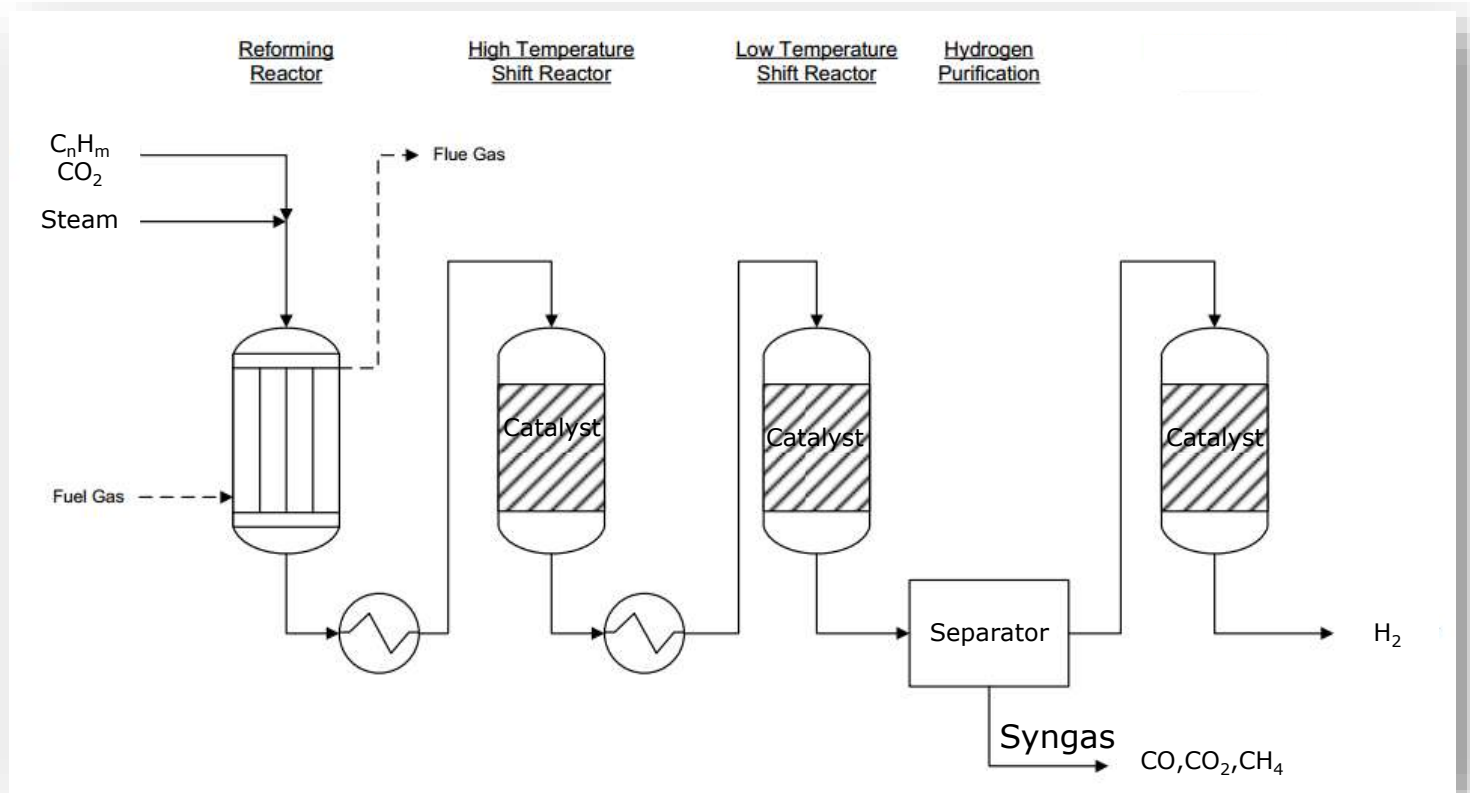

Fischer-Tropsch Synfuel Process



SASOL II & III, Secunda, S. Africa, FTL facility

Fischer-Tropsch **synthesis** [150–300 °C (302–572 °F)] → mix of alkanes

Process: Catalytic conversion Syngas →

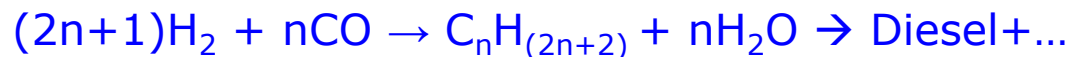

For methane feedstock → steam reforming, $CH_4 + H_2O \rightarrow CO + 3 H_2$

In addition, competing reactions → small amounts of alkenes, alcohols, oxygenated hydrocarbons. Common catalysts: Co, Fe, Ru (Ni for methanation).

Fischer-Tropsch Products

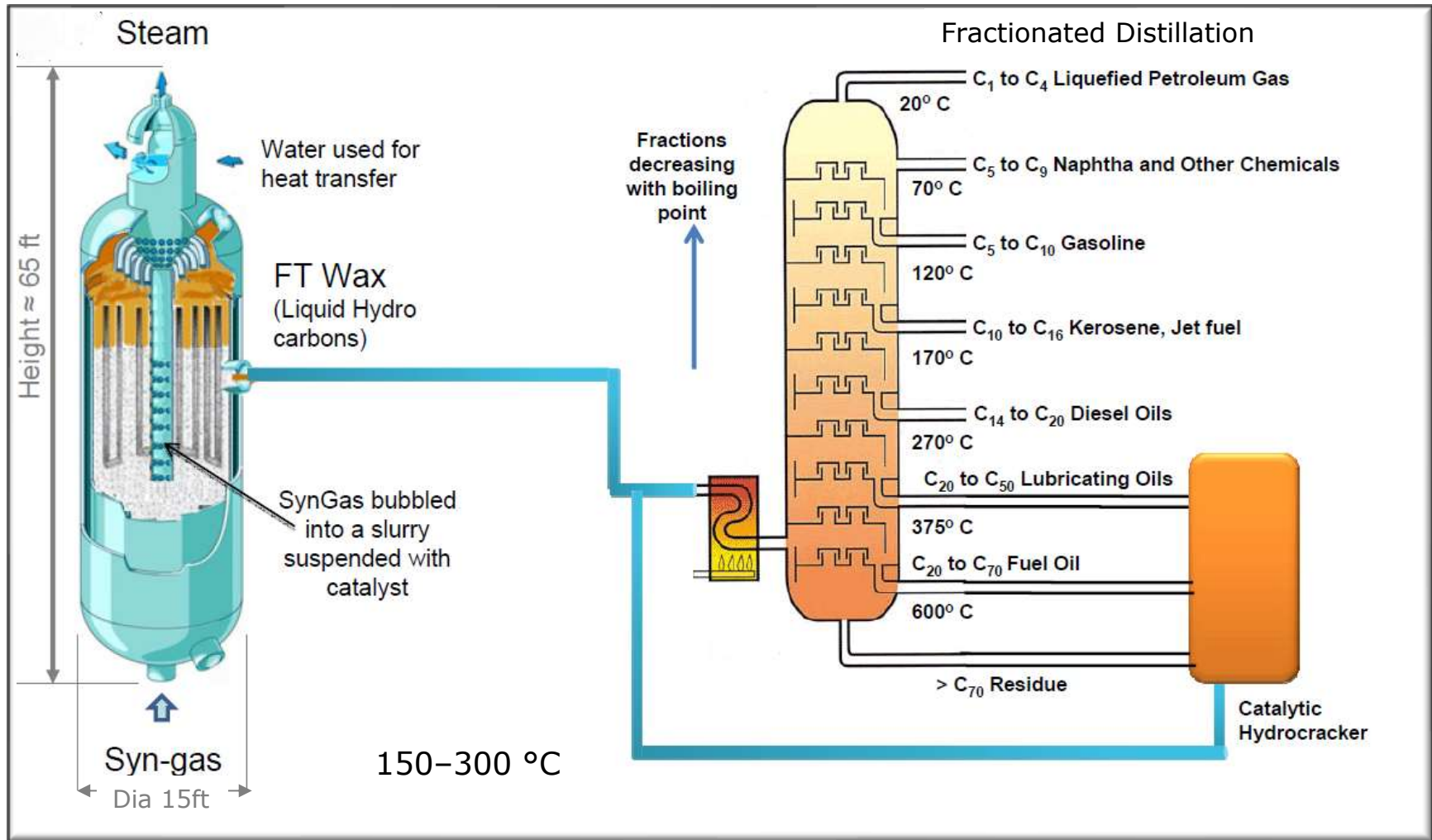

20

Energy_from_Biomass

Biomass Pyrolysis

Property	Unit	Value
C	wt%	46
H	wt%	7
N	wt%	< 0.01
O (Balance)	wt%	47
Water content	wt%	25
Ash content	wt%	0.02
Solids content	wt%	0.04
Density	kg/m ³	1,170
LHV	MJ/kg	16
LHV	MJ/Ltr	19
pH (Formic, acetic acids)	-	2.9
Kinematic viscosity (40 °C)	cSt	13

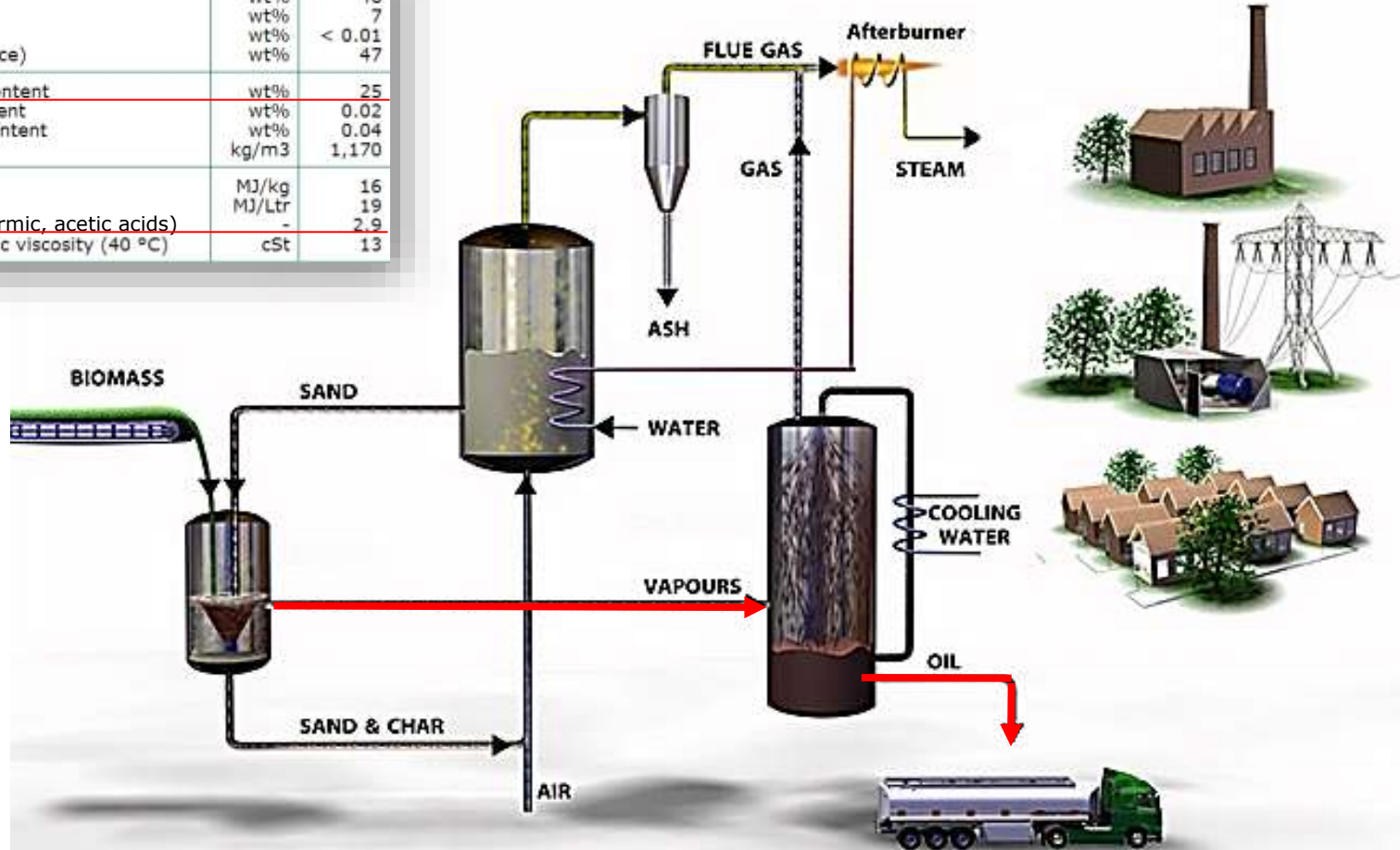

Fast pyrolysis: organic materials heated to 450 - 600 °C **in the absence of air** → organic vapors, pyrolysis gases, charcoal. Condense vapors to bio-oil. Typical conversion (60-75) wt.% of feedstock. **Ash**= (inorganic matter): limestone, iron, aluminum, clay, silica, and trace elements Zn, Co, B, Pb, As, Cd, Cr, Se (concentrations < 1000 ppm).

Pyrolysis Plant



23

Energy_from_Biomass

W. Udo S

Biological Bio-Ethanol Production

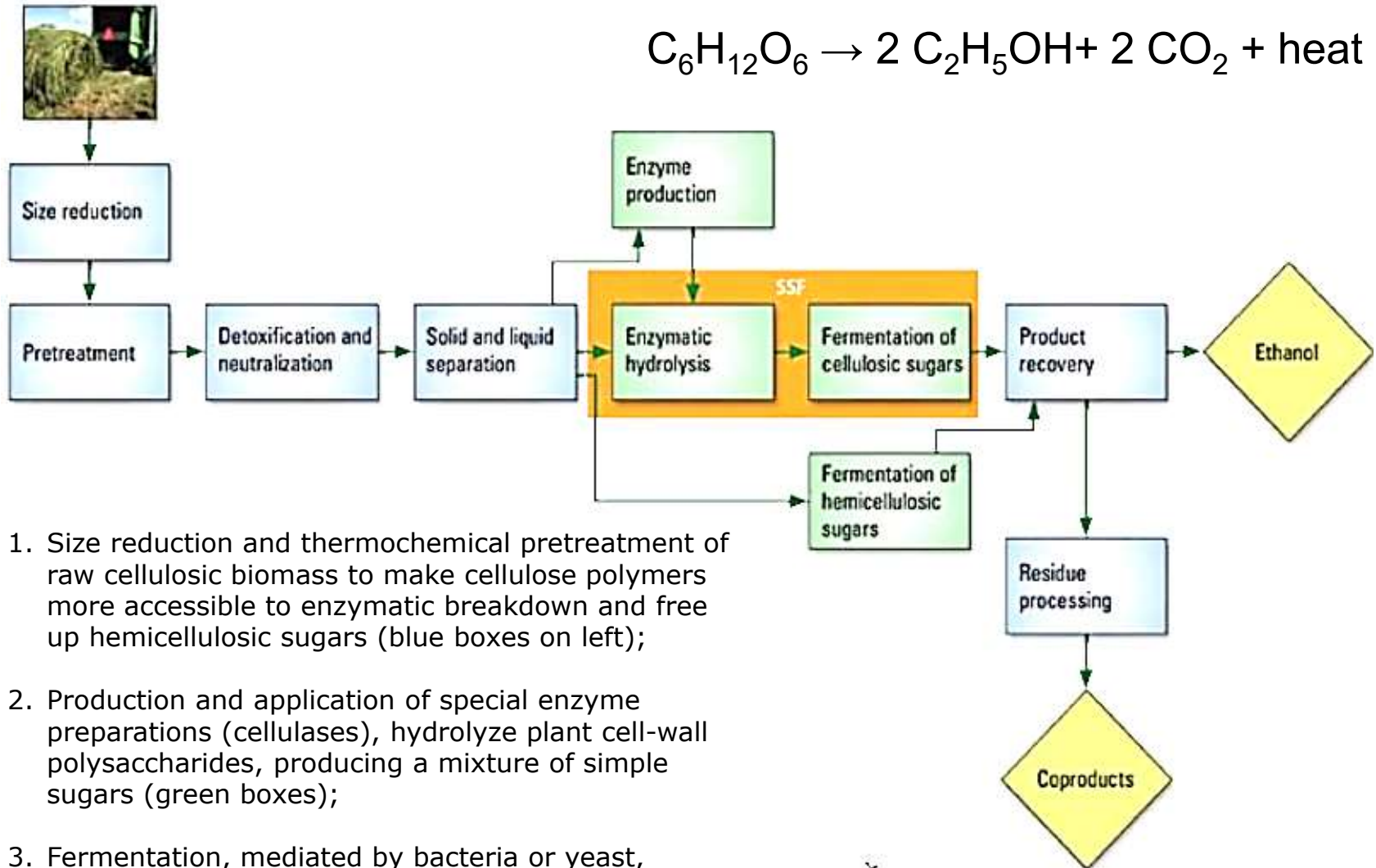
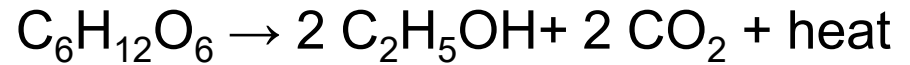

1. Size reduction and thermochemical pretreatment of raw cellulosic biomass to make cellulose polymers more accessible to enzymatic breakdown and free up hemicellulosic sugars (blue boxes on left);
2. Production and application of special enzyme preparations (cellulases), hydrolyze plant cell-wall polysaccharides, producing a mixture of simple sugars (green boxes);
3. Fermentation, mediated by bacteria or yeast, sugars \rightarrow ethanol +co-products (yellow diamonds).
4. Distillation/dehydration to remove water.

Biomass Renewable Electricity Capacity and Generation

US Energy Information Administration: Energy Outlook
 US: Diminishing importance of biomass for *electricity generation (7%)*. **2023**,
 Biomass produced 5% of total U.S.
 energy consumption, or about **4,978 trillion British thermal units (BTU)**.

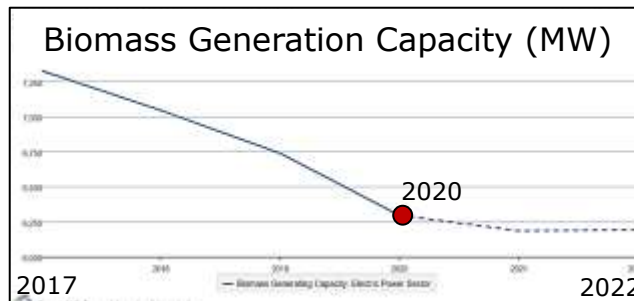

25

Energy_from_Biomass

	Year		
	2020	2021	2022
Electric Generating Capacity (MW)			
Electric Power Sector (a)			
Biomass	6,295	6,184	6,190
Waste	3,790	3,822	3,829
Wood	2,505	2,362	2,362
Conventional Hydroelectric	78,671	78,765	78,840
Geothermal	2,483	2,500	2,525
Large-Scale Solar (b)	47,586	63,333	81,531
Wind	118,045	135,042	141,903
Other Sectors (c) Not Electricity			
Biomass	6,302	6,289	6,281
Waste	777	778	778
Wood	5,525	5,510	5,503
Conventional Hydroelectric	279	279	279
Large-Scale Solar (b)	468	538	541
Small-Scale Solar (d)	27,724	33,487	41,276
Residential Sector	17,238	21,354	26,865
Commercial Sector	8,430	9,892	11,893
Industrial Sector	2,056	2,241	2,518
Wind	346	346	346

Renewable Electricity Generation (billion kilowatthours) (GWh)			
Electric Power Sector (a)			
Biomass	27.5	27.1	26.3
Waste	16.1	15.6	15.6
Wood	11.4	11.5	10.8
Conventional Hydroelectric	289.9	254.6	267.7
Geothermal	16.5	16.0	16.0
Large-Scale Solar (b)	90.1	114.3	145.7
Wind	336.7	377.3	420.4
Other Sectors (c) Not Electricity			
Biomass	28.6	28.0	28.0
Waste	2.7	2.7	2.7
Wood	25.8	25.3	25.3
Conventional Hydroelectric	1.2	1.2	1.2
Large-Scale Solar (b)	0.8	0.9	0.9
Small-Scale Solar (d)	41.7	49.8	61.6
Residential Sector	25.4	30.6	38.9
Commercial Sector	12.9	15.3	18.3
Industrial Sector	3.5	3.9	4.3
Wind	0.8	1.0	0.9

Transportation Fuels

		2023	2024	2025	2026
Total Biofuels Consumption (million barrels per day)		1.26	1.31	1.21	1.28
Fuel Ethanol Blended into Motor Gasoline (millio		0.93	0.93	0.93	0.93
Biodiesel Consumption (million barrels per day)		0.13	0.13	0.08	0.09
Biodiesel Product Supplied (million barrels		0.08	0.08	0.04	0.05
Biodiesel Net Inputs (million barrels per day)		0.05	0.04	0.03	0.04
Renewable Diesel Consumption (million barrels per		0.19	0.24	0.17	0.22
Renewable Diesel Product Supplied (million		0.18	0.23	0.15	0.21
Renewable Diesel Net Inputs (million barrel		0.01	0.01	0.01	0.01
Other Biofuel Consumption (million barrels per c		0.02	0.02	0.04	0.05
Total Motor Gasoline Consumption (million barrels per		8.94	8.97	8.89	8.88

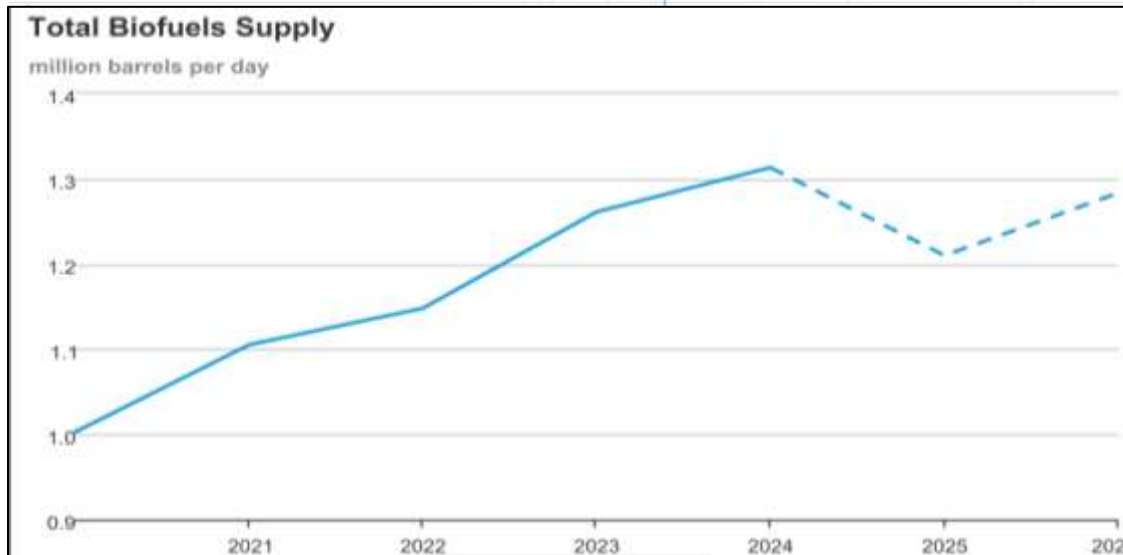

7.96	7.95
0.93	0.93

26
Energy_from_Biomass

Agenda

- World biomass inventory
 - Global challenges: Tree losses, deforestation of tropical/rainl forests
- Biomass energy resources, farming and harvesting
 - Renewable biomass principle,
 - US geographical bio-energy farming areas
 - Biomass energy density, heating value, GHG emission
- Biomass-Energy conversion methods
 - Direct combustion
 - Biomass to gas and liquid, ethanol production
 - pyrolysis, Fischer-Tropsch process
- Current biomass utilization
 - Transportation fuels, ethanol, biodiesel
 - Share in total electricity generation
- Strategic Issues biomass utilization